

EK

litebarpro12Q

RGBW one-meter LED batten
and 12 x 1 pixel mappable matrix

EK

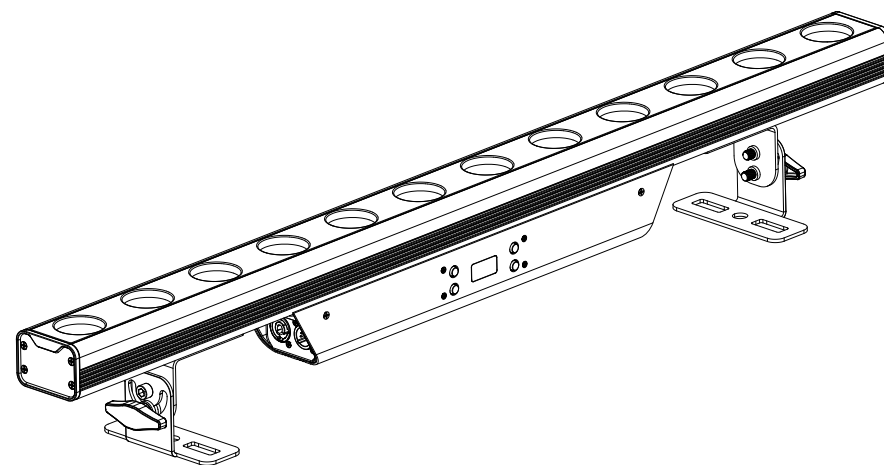



WARNING! Before carrying out any operations with the unit, carefully read this instruction manual and keep it with care for future reference. It contains important information about the installation, usage and maintenance of the unit.



SAFETY

General instruction

- The products referred to in this manual conform to the European Community Directives and are therefore marked with **CE**.
- The unit is supplied with hazardous network voltage (230V~). Leave servicing to skilled personnel only. Never make any modifications on the unit not described in this instruction manual, otherwise you will risk an electric shock.
- Connection must be made to a power supply system fitted with efficient earthing (Class I appliance according to standard EN 60598-1). It is, moreover, recommended to protect the supply lines of the units from indirect contact and/or shorting to earth by using appropriately sized residual current devices.
- The connection to the main network of electric distribution must be carried out by a qualified electrical installer. Check that the main frequency and voltage correspond to those for which the unit is designed as given on the electrical data label.
- This unit is not for home use, only professional applications.
- Never use the fixture under the following conditions:
 - in places subject to vibrations or bumps;
 - in places with a temperature of over 40 °C.
- Make certain that no inflammable liquids, water or metal objects enter the fixture.
- Do not dismantle or modify the fixture.
- All work must always be carried out by qualified technical personnel. Contact the nearest sales point for an inspection or contact the manufacturer directly.
- If the unit is to be put out of operation definitively, take it to a local recycling  plant for a disposal which is not harmful to the environment.

Warnings and installation precautions

- If this device will be operated in any way different to the one described in this manual, it may suffer damage and the guarantee becomes void. Furthermore, any other operation may lead to dangers like short circuit, burns, electric shock, etc.
- Before starting any maintenance work or cleaning the projector, cut off power from the main supply.
- Always additionally secure the projector with the safety rope. When carrying out any work, always comply scrupulously with all the regulations (particularly regarding safety) currently in force in the country in which the fixture's being used.
- Install the fixture in a well ventilated place.
- Keep any inflammable material at a safe distance from the fixture.
- Shields, lenses or ultraviolet screens shall be changed if they have become damaged to such an extent that their effectiveness is impaired.
- The lamp (LED) shall be changed if it has become damaged or thermally deformed.
- Never look directly at the light beam. Please note that fast changes in lighting, e. g. flashing light, may trigger epileptic seizures in photosensitive persons or persons with epilepsy.
- Do not touch the product's housing when operating because it may be very hot.

3.16 FACTORY RESET

The LITEBARPRO 12Q provides a factory reset function to restore all default values:

- Press the MENU button until the display shows **Reset Factory** , then press ENTER.
- Press the UP/DOWN buttons to select **Yes** , then press ENTER.

3.17 PHOTOMETRICS

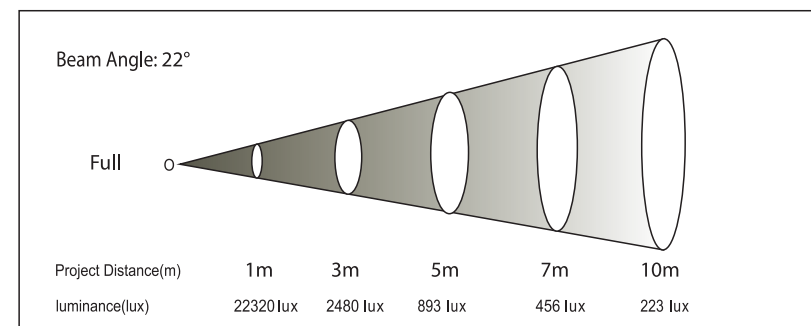

3.13 FIXTURE SETTINGS

It is possible to change the parameter values in the following ways:

Dimmer

- Enter in Dimmer mode to select specific dimming curve, press the button MENU so many times until shows **Dimmer Mode**, and press the button ENTER to confirm.
- Press the button UP/DOWN to select **Off - Dimmer 1 - Dimmer 2 - Dimmer 3**.
- Press ENTER button to store, then press MENU to return to main menu

BackLite

- To activate Backlight display press the button MENU so many times until shows **Back Light**, and press the button ENTER to confirm.
- Press the button UP/DOWN to select **On - 10S - 20S - 30S**.
- Press ENTER button to confirm the selection, then press MENU to return to main menu

3.14 FIXTURE INFORMATION

Fixture Hours

Show the fixture working hours.

- Press the button MENU so many times until shows **Information**. Press the button ENTER to confirm
- Using the button UP/DOWN to select **Fixture Hours**, then press the button ENTER to confirm
- Then the display will show the working hours. Press MENU to return to main menu

Version

Show the fixture firmware version.

- Press the button MENU so many times until shows **Information**
- Select through the button UP/DOWN the **Version** menu voice.
- The display will show the firmware data. Press MENU to return to main menu

3.15 WHITE BALANCE

Enter the White balance to adjust the **Red, Green, Blue** and **White** levels to achieve different whites.

- Press the button MENU so many times until shows **White Balance**, and press the button ENTER to confirm.
- Select the color **R, G, B, W** using the UP/DOWN buttons, then press ENTER.
- Using UP/DOWN button, select the desired color value **125 - 255**.
- Press ENTER button to continue to the next color **R, G, B, W**.
- Continue until the desired mix is obtained.
- Press the MENU button to go back or wait a few seconds to exit the setup menu.

TABLE OF CONTENTS

Safety

General instructions
Warnings and installation precautions
General information

1 Introduction

1.1 Description and Technical specifications

1.2 Maintenance

Cleaning the unit
Trouble shooting

1.3 Operating elements and connections

2 Installation

2.1 Mounting
2.2 Dimensions

3 Functions and settings

3.1 Operation
3.2 Basic
3.3 Menu structure
3.4 Auto show
3.5 Static mode
3.6 Master/Slave mode
3.7 Linking
3.8 DMX configuration
3.9 DMX addressing
3.10 Connection of the DMX line
3.11 Construction of the DMX termination
3.12 DMX control
3.13 Fixture settings
3.14 Fixture information
3.15 White balance calibration
3.16 Factory reset
3.17 Photometrics

Packing content

LITEBARPRO 12Q
• Mounting bracket (2 pcs.)
• Power cable
• User manual

INTRODUCTION

The LITEBARPRO 12Q is a quad-color (4-in-one) RGBW one-meter LED batten that delivers vibrant linear color washes and an individually controllable 12 x 1 pixel matrix.

FEATURES

- Deep, saturated, perfectly-mixed colors for wall grazing and linear washes
- Mounting brackets allow fixture to be flown or floor-mounted
- Rugged diecast body and production-grade construction
- Color and white presets available via onboard menu or DMX
- Silent operation with advanced fanless thermal management
- Onboard library of 13 dynamic preprogrammed light shows
- Custom color mixing and adjustable white balance
- Menu display backlight auto blackout
- Four selectable dimming curves
- Power linking
- DMX control

SPECIFICATIONS

Light Source:	14W RGBW LED (x12)
Beam Angle:	22°
Field Angle:	38°
Output (lux):	893 lux @ 5 meters
Color Output:	RGBW
Pixel Matrix:	12 x 1
Strobe:	0-30 Hz
Dimming:	4 dimming curve modes
Control:	DMX
DMX Channels:	4 / 6 / 10 / 48 / 53
Display:	OLED menu display
Mains:	100 - 240 VAC, 50/60 Hz
Consumption:	95W
Power connections:	Powercon In/Out
Power linking:	26 units @ 230V / 14 units @ 230V
Data connections:	5-pin XLR In/Out for DMX
Housing:	Diecast Aluminum
Finish:	Matte black
IP rating:	IP20
Cooling:	Convection
Dimensions:	994 x 127 x 138 mm
Weight:	5.4 KG

3.12 DMX CONTROL

10 CHANNEL MODE (cont'd)

9	Auto Speed	000-255	Auto Speed Slow to Fast
10	Dimmer Speed Mode	000-051	Preset dimmer speed from display menu
		052-101	Dimmer speed mode off
		102-152	Dimmer speed mode1 (fast speed)
		153-203	Dimmer speed mode2 (middle speed)
		204-255	Dimmer speed mode3 (slow speed)

53 CHANNEL MODE

	Function	Value	Percent/Setting
1	Red1	000-255	0~100%
2	Green1	000-255	0~100%
3	Blue1	000-255	0~100%
4	White1	000-255	0~100%
.....			
45	Red 12	000-255	0~100%
46	Green 12	000-255	0~100%
47	Blue 12	000-255	0~100%
48	White12	000-255	0~100%
49	Auto programs	000-010	No Function
		011-030	Auto program 1
		031-050	Auto program 2
		051-070	Auto program 3
		071-090	Auto program 4
		091-110	Auto program 5
		111-130	Auto program 6
		131-150	Auto program 7
		151-170	Auto program 8
		171-190	Auto program 9
		191-210	Auto program 10
		211-230	Auto program 11
		231-250	Auto program 12
251-255	Auto program 13		
50	Auto Speed	000-255	Auto Speed Slow to Fast
51	Dimmer	000-255	0~100%
52	Strobe	000-010	No Function
		011-255	Strobe Slow to Fast
53	Dimmer Speed Mode	000-051	Preset dimmer speed from display menu
		052-101	Dimmer speed mode off
		102-152	Dimmer speed mode1 (fast speed)
		153-203	Dimmer speed mode2 (middle speed)
		204-255	Dimmer speed mode3 (slow speed)

3.12 DMX CONTROL

10 CHANNEL MODE

	Function	Value	Percent/Setting
1	Dimmer	000-255	0~100%
2	Red	000-255	0~100%
3	Green	000-255	0~100%
4	Blue	000-255	0~100%
5	White	000-255	0~100%
6	Strobe	000-010	No Function
		011-255	Strobe Slow to Fast
7	Color Macro	000~010	No Function
		011~030	R 100%, G 0~100%, B 0%
		031~050	R 100%~0%, G 100%, B 0%
		051~070	R 0%, G 100%, B 0~100%
		071~090	R 0% G 100%~0% B 100%
		091~110	R 0%~100% G 0% B 100%
		111~130	R 100% G 0% B 100%~0%
		131~150	R 100% G 0%~100% B 0%~100%
		151~170	R 100%~0% G 100%~0% B 100%
		171~200	R 100% G 100% B 100%
		201~205	Color 1
		206~210	Color 2
		211-215	Color 3
		216-220	Color 4
		221-225	Color 5
		226-230	Color 6
		231-235	Color 7
236-240	Color 8		
241-245	Color 9		
246-250	Color 10		
251-255	Color 11		
8	Auto programs	000-010	No Function
		011-030	Auto program 1
		031-050	Auto program 2
		051-070	Auto program 3
		071-090	Auto program 4
		091-110	Auto program 5
		111-130	Auto program 6
		131-150	Auto program 7
		151-170	Auto program 8
		171-190	Auto program 9
		191-210	Auto program 10
		211-230	Auto program 11
		231-250	Auto program 12
251-255	Auto program 13		

- 1.2 - MAINTENANCE

MAINTENANCE AND CLEANING THE UNIT

- Make sure the area below the installation place is free from unwanted persons during setup.
- Switch off the unit, unplug the main cable and wait until the unit has cooled down.
- All screws used for installing the device and any of its parts should be tightly fastened and should not be corroded.
- Housings, fixations and installation spots (ceiling, trusses, suspensions) should be totally free from any deformation.
- The main cables must be in impeccable condition and should be replaced immediately even when a small problem is detected.
- It is recommended to clean the front at regular intervals, from impurities caused by dust, smoke, or other particles to ensure that the light is radiated at maximum brightness. For cleaning, disconnect the main plug from the socket. Use a soft, clean cloth moistened with a mild detergent. Then carefully wipe the part dry. For cleaning other housing parts use only a soft, clean cloth. Never use a liquid, it might penetrate the unit and cause damage to it.

TROUBLESHOOTING

Problems	Possible causes	Checks and remedies
Fixture does not light up	<ul style="list-style-type: none"> • No mains supply • Dimmer fader set to 0 • All color faders set to 0 • Faulty LED • Faulty LED board 	<ul style="list-style-type: none"> • Check the power supply voltage • Increase the value of the dimmer channels • Increase the value of the color channels • Replace the LED board • Replace the LED board
General low light intensity	<ul style="list-style-type: none"> • Dirty lens assembly • Misaligned lens assembly 	<ul style="list-style-type: none"> • Clean the fixture regularly • Install lens assembly properly
Fixture does not power up	<ul style="list-style-type: none"> • No power • Loose or damaged power cord • Faulty internal power supply 	<ul style="list-style-type: none"> • Check for power on power outlet • Check power cord • Replace internal power supply
Fixture does not respond to DMX	<ul style="list-style-type: none"> • Wrong DMX addressing • Damaged DMX cables • Bouncing signals 	<ul style="list-style-type: none"> • Check control panel and unit addressing • Check DMX cables • Install terminator as suggested

Contact an authorized service center in case of technical problems or not reported in the table can not be resolved by the procedure given in the table.

1.3 OPERATING ELEMENTS AND CONNECTIONS

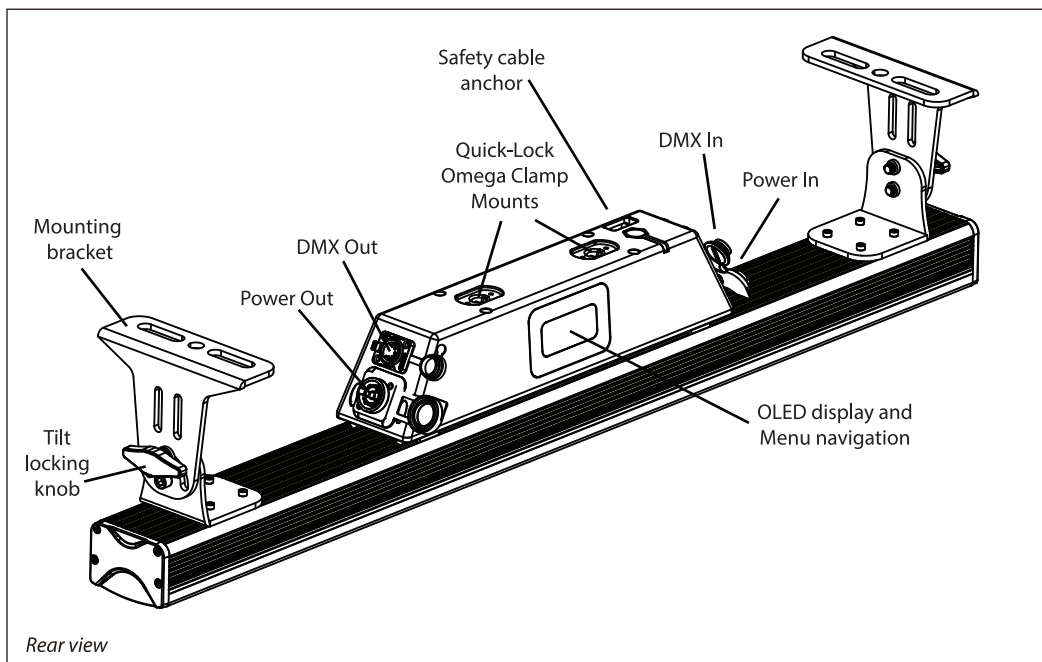

1. TILT LOCKING KNOB

2. MOUNTING BRACKET

3. POWER OUT

4. DMX OUT

5. QUICK-LOCK MOUNTS for Omega clamps

6. SAFETY CABLE ANCHOR

7. DMX IN

8. POWER IN

9. OLED DISPLAY and MENU NAVIGATION

3.12 DMX CONTROL

4 CHANNEL MODE

	Function	Value	Percent/Setting
1	Red	000-255	0~100%
2	Green	000-255	0~100%
3	Blue	000-255	0~100%
4	White	000-255	0~100%

6 CHANNEL MODE

	Function	Value	Percent/Setting
1	Dimmer	000-255	0~100%
2	Red	000-255	0~100%
3	Green	000-255	0~100%
4	Blue	000-255	0~100%
5	White	000-255	0~100%
6	Strobe	000-010 011-255	No Function Strobe Slow to Fast

48 CHANNEL MODE

	Function	Value	Percent/Setting
1	Red1	000-255	0~100%
2	Green1	000-255	0~100%
3	Blue1	000-255	0~100%
4	White1	000-255	0~100%
.....			
45	Red 12	000-255	0~100%
46	Green 12	000-255	0~100%
47	Blue 12	000-255	0~100%
48	White12	000-255	0~100%

3.10 CONNECTION OF THE DMX LINE

DMX connection employs standard XLR connectors. Use shielded pair-twisted cables with 120Ω impedance and low capacity.

The following diagram shows the connection mode:

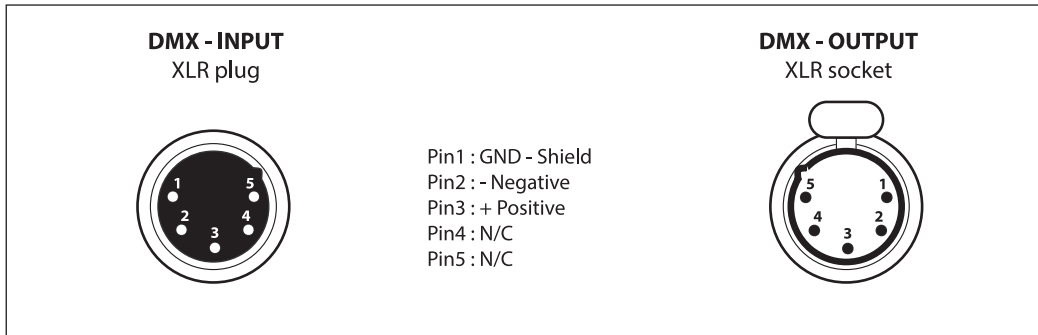

ATTENTION

The screened parts of the cable (sleeve) must never be connected to the system's earth, as this would cause faulty fixture and controller operation.

Over long runs can be necessary to insert a DMX level matching amplifier.

For those connections the use of balanced microphone cable is not recommended because it cannot transmit control DMX data reliably.

- Connect the controller DMX input to the DMX output of the first unit.
- Connect the DMX output to the DMX input of the following unit. Connect again the output to the input of the following unit until all the units are connected in chain.
- When the signal cable has to run longer distance is recommended to insert a DMX termination on the last unit.

3.11 CONSTRUCTION OF THE DMX TERMINATION

The termination avoids the risk of DMX 512 signals being reflected back along the cable when they reach the end of the line: under certain conditions and with certain cable lengths, this could cause them to cancel the original signals.

The termination is prepared by soldering a 120Ω 1/4 W resistor between pins 2 and 3 of the 5-pin male XLR connector, as shown in figure.

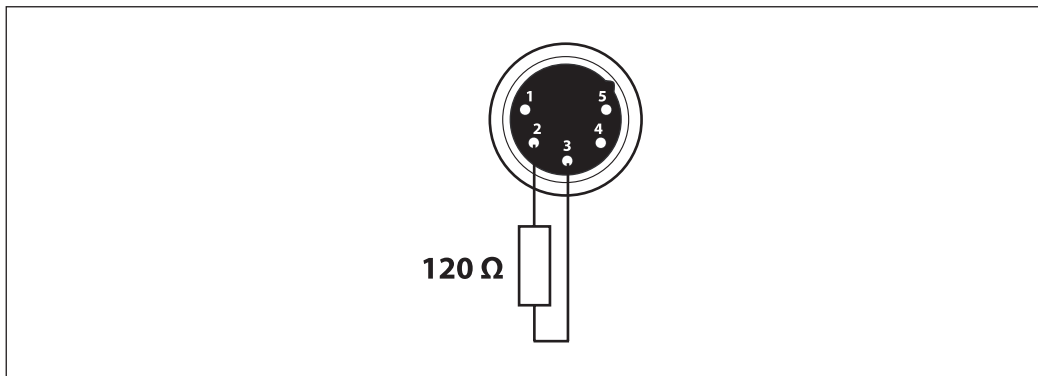

2.2 DIMENSIONS

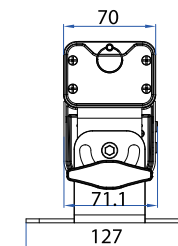
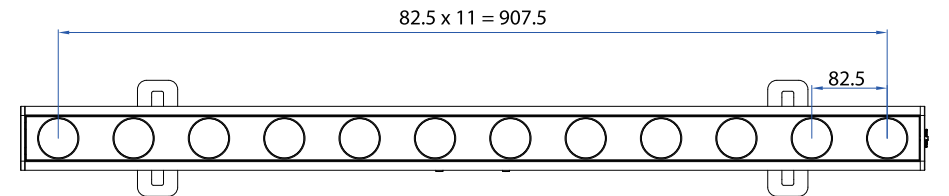
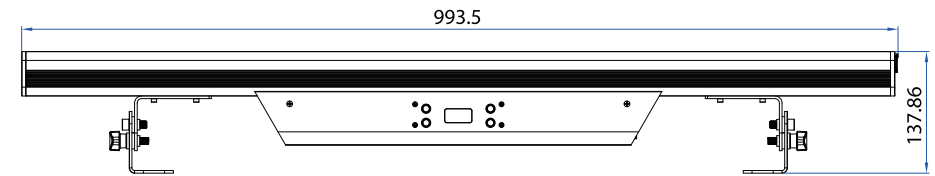
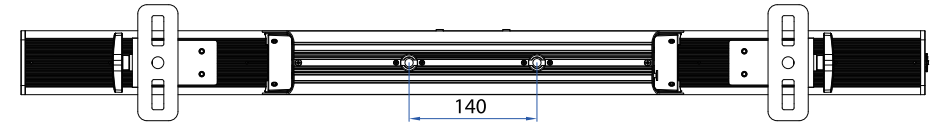

- 2 - INSTALLATION

2.1 MOUNTING

LITEBARPRO 12Q may be surface-mounted to an even wall or floor, or mounted upside down to a cross arm. For fixing, stable mounting clips are required. The mounting place must be of sufficient stability and be able to support a weight of 10 times of the unit's weight.

When carrying out any installation, always comply scrupulously with all the regulations (particularly regarding safety) currently in force in the country in which the fixture's being used.

- Install the projector at a suitable location by means of Quick-Lock mounting brackets (1).
- Always additionally secure the projector with the safety cable to prevent falling down (2). Attach the safety cable at a suitable position so that the maximum fall of the fixture will be 20 cm.
- Floor/wall mounting: adjust the fixture's tilt and use the knob to slightly release or tighten the locking mechanism of the bracket as necessary (2).

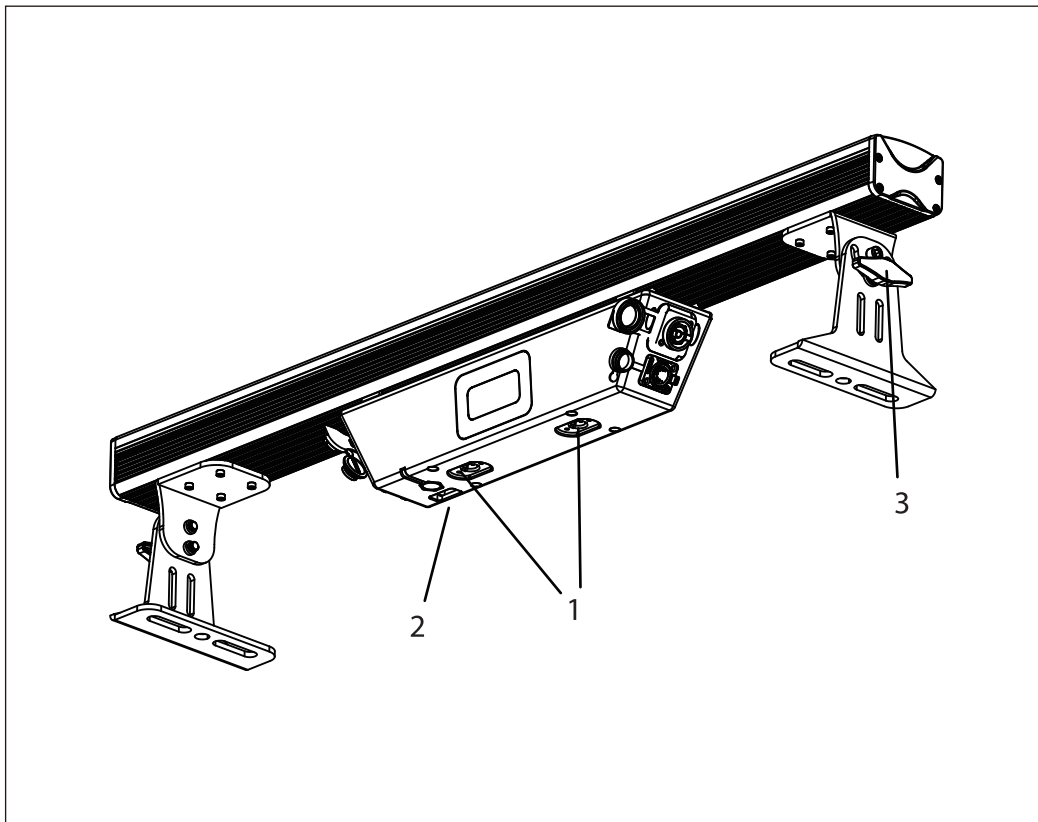

3.8 DMX CONFIGURATION

LITEBARPRO 12Q offers five different DMX modes:

- Press the MENU button until [DMX CHANNEL] is displayed, then press the ENTER button to confirm.
- Select the desired DMX configuration (4CH - 6CH - 10CH - 48CH -53CH) using the UP/DOWN buttons.

3.9 DMX ADDRESSING

- Press the MENU button until [DMX ADDRESS] is displayed, then press ENTER to confirm.
- Press UP/DOWN button to select the desired value (001-512). Press and hold to scroll quickly.
- Press ENTER button to store.
- Press the MENU button to go back or to meet the waiting time to exit the setup menu.

To operate the LITEBARPRO 12Q with a light controller, adjust the DMX start address for the first a DMX channel. If e. g. address 33 on the controller is provided for controlling the function of the first DMX channel, adjust the start address 33 on the LITEBARPRO 15QX IP and follow a similar method as shown.

An example with the start address 33 is shown below:

Number of DMX channels	Start address (example)	DMX Address occupied	Next possible start address for unit No. 1	Next possible start address for unit No. 2	Next possible start address for unit No. 3
4	33	33-36	37	41	45

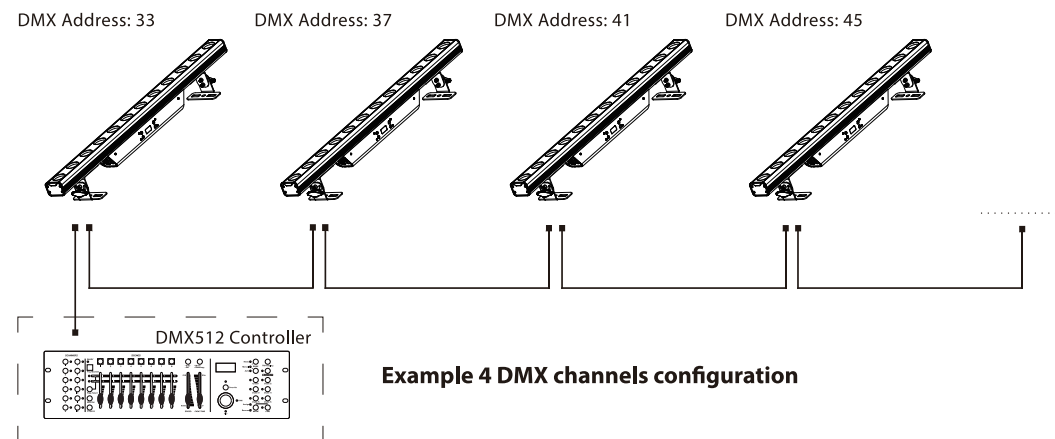

3.4 AUTO SHOW

If no DMX control signal is present at the DMX INPUT, the unit independently runs through its auto show programs:

- Press the MENU button until the display shows **Auto Show**, then press the button ENTER.
- Press the button UP/DOWN to switch between the show (**Auto 1 - 13**). The unit will operate in show mode.
- Use the UP/DOWN buttons to select the desired run speed slow-fast (**0-100**).
- Press the ENTER button to save the setting.

IMPORTANT: Programs **Auto 1 - 13** are fully pre-programmed and will not be altered by changes. Instead, **Manual Color** mode allows to combine the colors **Red - Green - Blue - White**.

- Press the button MENU so many times until the display shows **Static**, then press the button ENTER.
- Through the button UP/DOWN select **Manual Color**, then press the button ENTER.
- Select the color **Red - Green - Blue - White** through the buttons UP/DOWN.
- Press the button ENTER to confirm.
- Set the value (**000 - 255**), through the buttons UP/DOWN.
- Press the MENU button to go back or to meet the waiting time to exit the setup menu.

3.5 STATIC MODE

This fixture has the ability to accept custom static color settings. Access these chases via the control panel on the back of the fixture.

- To enable the static mode, press MENU repeatedly until **Static** shows on the display.
- Press the button ENTER.
- Through the button UP/DOWN select **Fixed Color**, then press the button ENTER.
- Select the desired preset color (**R - G - B - W - GB - RB - RG - RGB - RW - GW - BW - RGW - RBW - GBW - RGBW**) using the button UP/DOWN.
- Press the button ENTER to save the setting.
- Press the MENU button to go back. Or, after a few seconds, the menu returns to the main screen.

3.6 MASTER/SLAVE MODE

This mode will allow you to link up the units together without a controller. Choose a unit to function as the Master. The unit must be the first unit in line; other units will work as slave with the same effect.

- Press the button MENU so many times until the display shows **Master/Slave** and press the button ENTER.
- Press UP/DOWN to set the unit as master or slave (**Master/Slave**).
- Select the desired program (see section 3.4).
- Use standard DMX cables to daisy chain your units together via the DMX connector on the rear of the unit. For longer cable runs, using a DMX terminator as described in this manual is recommended.

3.7 LINKING

Several units may be interconnected in order to control all further slave units to the same effect of the master unit.

1. Connect the DMX OUT of the master unit via 5-pin XLR cable to the DMX IN of the first slave unit.
2. Connect the DMX OUT of the first slave unit to the DMX IN of the second slave unit, etc. until all units are connected in a chain.

- 3 - FUNCTIONS AND SETTINGS

3.1 OPERATION

Connect the supplied main cable to a socket (100-240V~/50-60Hz). Then the unit is ready for operation and can be operated via a DMX controller or it independently performs its show program in succession. To switch off, disconnect the mains plug from the socket. For a more convenient operation it is recommended to connect the unit to a socket which can be switched on and off via a light switch.

3.2 BASIC

Access control panel functions using the four panel buttons located adjacent to the OLED display.

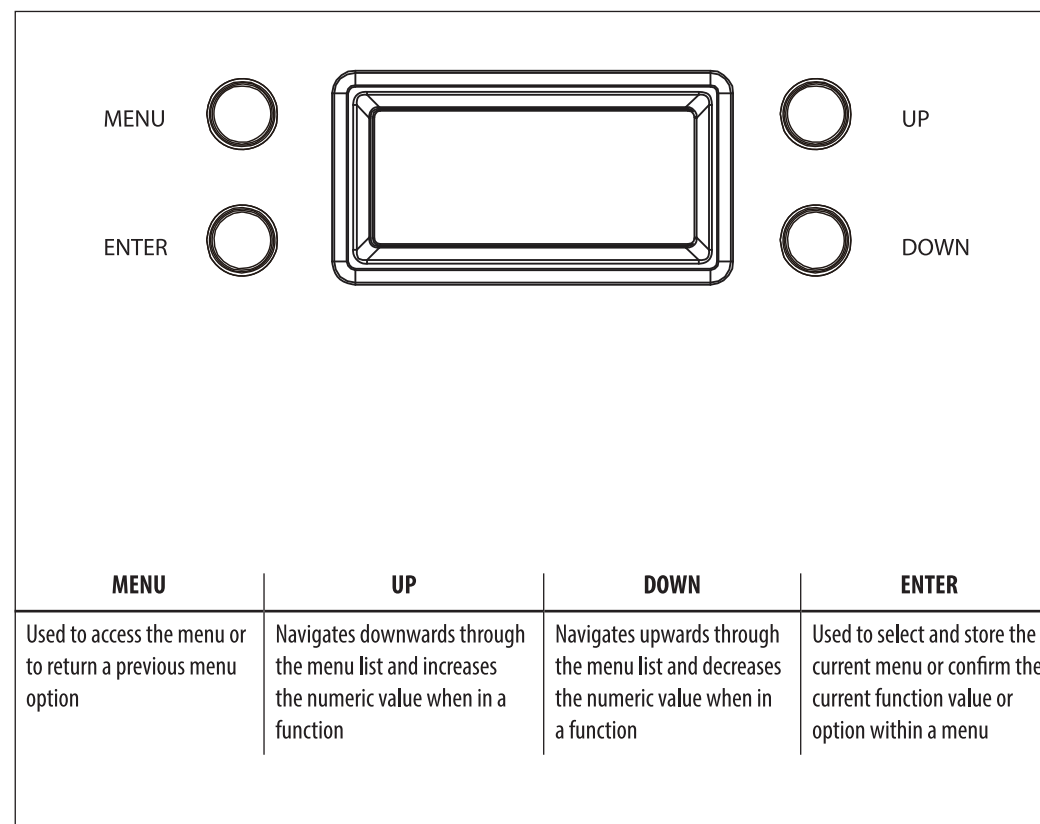

3.3 MENU STRUCTURE

Main Menu	Submenu	Submenu	Default settings	
DMX Address	<001 ~ 512>		Default: 001	
DMX Channel	4 Ch		Default: 10 CH	
	6 Ch			
	10 Ch			
	48 Ch			
	53 Ch			
Static	Fixed Color	R		
		G		
		B		
		W		
		GB		
		RB		
		RG		
		RGB		
		RW		
		GW		
		BW		
		RGW		
		RBW		
	GBW			
	RGBW			
	Manual Color Mixer	Red	<0-255>	Default: RGBW=255
		Green	<0-255>	
		Blue	<0-255>	
		White	<0-255>	
	Auto Show	Auto 1	<0-100>	Default: Auto 1; Speed: 100
Auto 2		<0-100>		
Auto 3		<0-100>		
Auto 4		<0-100>		
Auto 5		<0-100>		
Auto 6		<0-100>		
Auto 7		<0-100>		
Auto 8		<0-100>		
Auto 9		<0-100>		
Auto 10		<0-100>		
Auto 11		<0-100>		
Auto 12		<0-100>		
Auto 13		<0-100>		
Dimmer Mode	Off		Default: Off	
	Dimmer 1			
	Dimmer 2			
	Dimmer 3			
Master/Slave	Master		Default: Slave	
	Slave			

3.3 MENU STRUCTURE (cont'd)

White Balance	Off		Default: Off		
	Manual			Red	<125-255>
				Green	<125-255>
				Blue	<125-255>
	White	<125-255>			
Back Light	On		Default: On		
	10S				
	20S				
	30S				
Information	Fixture Hours	<9999H>			
	Version	<V1.0>			
Reset Factory	No				
	Yes				