

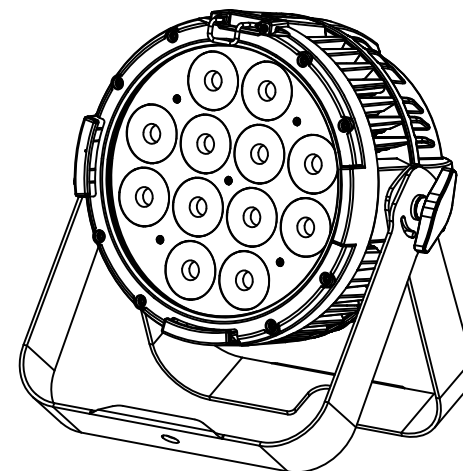

# liteparó12QX

Outdoor-rated Quad-color LED washlight  
designed for professional touring and production





**WARNING!** Before carrying out any operations with the unit, carefully read this instruction manual and keep it with care for future reference. It contains important information about the installation, usage and maintenance of the unit.



## SAFETY

### General instruction

- The products referred to in this manual conform to the European Community Directives and are therefore marked with **CE**.
- The unit is supplied with hazardous network voltage (230V~). Leave servicing to skilled personnel only. Never make any modifications on the unit not described in this instruction manual, otherwise you will risk an electric shock.
- Connection must be made to a power supply system fitted with efficient earthing (Class I appliance according to standard EN 60598-1). It is, moreover, recommended to protect the supply lines of the units from indirect contact and/or shorting to earth by using appropriately sized residual current devices.
- The connection to the main network of electric distribution must be carried out by a qualified electrical installer. Check that the main frequency and voltage correspond to those for which the unit is designed as given on the electrical data label.
- This unit is not for home use, only professional applications.
- Never use the fixture under the following conditions:
  - in places subject to vibrations or bumps;
  - in places with a temperature of over 40 °C.
- Make certain that no inflammable liquids, water or metal objects enter the fixture.
- Do not dismantle or modify the fixture.
- All work must always be carried out by qualified technical personnel. Contact the nearest sales point for an inspection or contact the manufacturer directly.
- If the unit is to be put out of operation definitively, take it to a local recycling  plant for a disposal which is not harmful to the environment.

### Warnings and installation precautions

- If this device will be operated in any way different to the one described in this manual, it may suffer damage and the guarantee becomes void. Furthermore, any other operation may lead to dangers like short circuit, burns, electric shock, etc.
- Before starting any maintenance work or cleaning the projector, cut off power from the main supply.
- Always additionally secure the projector with the safety rope. When carrying out any work, always comply scrupulously with all the regulations (particularly regarding safety) currently in force in the country in which the fixture's being used.
- Install the fixture in a well ventilated place.
- Keep any inflammable material at a safe distance from the fixture.
- Shields, lenses or ultraviolet screens shall be changed if they have become damaged to such an extent that their effectiveness is impaired.
- The lamp (LED) shall be changed if it has become damaged or thermally deformed.
- Never look directly at the light beam. Please note that fast changes in lighting, e. g. flashing light, may trigger epileptic seizures in photosensitive persons or persons with epilepsy.
- Do not touch the product's housing when operating because it may be very hot.

## 3.13 FIXTURE SETTINGS

It is possible to change the parameter values in the following ways:

### Dimmer

- Enter in Dimmer mode to select specific dimming curve, press the button MENU so many times until shows **Dimmer Mode**, and press the button ENTER to confirm.
- Press the button UP/DOWN to select **Off - Dimmer 1 - Dimmer 2 - Dimmer 3**.
- Press ENTER button to store, then press MENU to return to main menu

### BackLite

- To activate Backlight display press the button MENU so many times until shows **Back Light**, and press the button ENTER to confirm.
- Press the button UP/DOWN to select **On - 10S - 20S - 30S**.
- Press ENTER button to confirm the selection, then press MENU to return to main menu

### LED Frequency

- To adjust the frequency of the LEDs, press the MENU button repeatedly until the display shows **LED Frequency**, and then press the ENTER button.
- Select the frequency (**600 Hz - 25 kHz**) using the UP/DOWN buttons.
- To confirm, press the ENTER key, then press MENU to return to main menu

## 3.14 FIXTURE INFORMATION

### Fixture Hours

Show the fixture working hours.

- Press the button MENU so many times until shows **Information**. Press the button ENTER to confirm
- Using the button UP/DOWN to select **Fixture Hours**, then press the button ENTER to confirm
- Then the display will show the working hours. Press MENU to return to main menu

### Version

Show the fixture firmware version.

- Press the button MENU so many times until shows **Information**
- Select through the button UP/DOWN the **Version** menu voice.
- The display will show the firmware data. Press MENU to return to main menu

### Temperature

- To read the value of the internal temperature of the device, press the MENU button repeatedly until the display shows **Temperature**, and then press the ENTER button to read the value.
- Press the MENU button to go back or wait a few seconds to exit the setup menu.

## 3.15 WHITE BALANCE

Enter the White balance to adjust the **Red**, **Green**, and **Blue** levels to achieve different whites.

- Press the button MENU so many times until shows **White Balance**, and press the button ENTER to confirm.
- Select the color **R, G, B, W** using the UP/DOWN buttons, then press ENTER.
- Using UP/DOWN button, select the desired color value **125 - 255**.
- Press ENTER button to continue to the next color **R, G, B, W**.
- Continue until the desired mix is obtained.
- Press the MENU button to go back or wait a few seconds to exit the setup menu.

## 11 CHANNELS

MODE 11 Ch	FUNCTION	DMX Value
1	<b>DIMMER</b> 0~100%	000 - 255
2	<b>RED</b> 0~100%	000 - 255
3	<b>GREEN</b> 0~100%	000 - 255
4	<b>BLUE</b> 0~100%	000 - 255
5	<b>WHITE</b> 0~100%	000 - 255
6	<b>STROBE</b> No function Slow to fast	000 - 010 011 - 255
7	<b>COLOR MACRO + WHITE BALANCE</b> No function R:100% / G:0~100% / B:0 R:100%~0 / G:100% / B:0 R:0 / G:100% / B:0~100% R:0 / G:100%~0 / B:100% R:0~100% / G:0 / B:100% R:100% / G:0 / B:100%~0 R:100% / G:0~100% / B:0~100% R:100%~0 / G:100%~0 / B:100% R:100% / G:100% / B:100% / W:100% Color1 Color2 Color3 Color4 Color5 Color6 Color7 Color8 Color9 Color10 Color11	000-010 011-030 031-050 051-070 071-090 091-110 111-130 131-150 151-170 171-200 201-205 206-210 211-215 216-220 221-225 226-230 231-235 236-240 241-245 246-250 251-255
8	<b>COLOR TEMPERATURE</b> No function 3000K 4000K 5000K 6000K 7000K 8000K 9000K 10000K No Function	000-005 006-039 040-069 070-099 100-129 130-159 160-189 190-219 220-250 251-255

## 3.12 DMX CONTROL

MODE 11 Ch	FUNCTION	DMX Value
9	<b>AUTO PROGRAMS</b> No Function Auto Program 1 Auto Program 2 Auto Program 3 Auto Program 4 Auto Program 5	000 - 010 011 - 060 061 - 110 111 - 160 161 - 210 211 - 255
10	<b>AUTO SPEED</b> Slow to fast	000 - 255
11	<b>DIMMER SPEED</b> Preset dimmer speed from display menu Dimmer speed mode off Dimmer speed mode1 (fast speed) Dimmer speed mode2 (middle speed) Dimmer speed mode3 (slow speed)	000-051 052-101 102-152 153-203 204-255

## 6 CHANNELS

MODE 6 Ch	FUNCTION	DMX Value
1	<b>DIMMER</b> 0~100%	000 - 255
2	<b>RED</b> 0~100%	000 - 255
3	<b>GREEN</b> 0~100%	000 - 255
4	<b>BLUE</b> 0~100%	000 - 255
5	<b>WHITE</b> 0~100%	000 - 255
6	<b>STROBE</b> No function Slow to fast	000 - 010 011 - 255

## 4 CHANNELS

MODE 4 Ch	FUNCTION	DMX Value
1	<b>RED</b> 0~100%	000 - 255
2	<b>GREEN</b> 0~100%	000 - 255
3	<b>BLUE</b> 0~100%	000 - 255
4	<b>WHITE</b> 0~100%	000 - 255

## TABLE OF CONTENTS

**Safety**

General instructions  
Warnings and installation precautions  
General information

**1 Introduction**

1.1 Description and Technical specifications

**1.2 Maintenance**

Cleaning the unit  
Fuse replacement  
Trouble shooting

1.3 Operating elements and connections

**2 Installation**

2.1 Mounting  
2.2 Dimensions

**3 Functions and settings**

3.1 Operation  
3.2 Basic  
3.3 Menu structure  
3.35 W-DMX wireless setting  
3.4 Auto show  
3.5 Static mode  
3.6 Master/Slave mode  
3.7 Linking  
3.8 DMX configuration  
3.9 DMX addressing

**3.95 PHOTOMETRICS**

3.10 Connection of the DMX line  
3.11 Construction of the DMX termination  
3.12 DMX control  
3.13 Fixture settings  
3.14 Fixture information  
3.15 White balance

**Packing content**

LITEPARPRO 12QX  
• Mounting bracket  
• User manual

## INTRODUCTION

The LITEPARPRO 12QX is an outdoor-rated Quad-color LED washlight designed for professional touring and production.

### FEATURES

- 12 x 10W RGBW or RGBA LEDs
- Perfect color consistency in a compact package with extremely tight beam output
- Selectable PWM frequencies for flicker-free output and worry-free video
- Double mounting bracket allows fixture to be flown or floor-mounted
- Four selectable dimming curve modes (off, fast, medium, slow)
- Patented structural design delivers superior passive cooling
- Ultra-linear dimming technology for flawless color mixing
- Advanced color management with adjustable white balance
- Silent operation suitable for broadcast environments
- Indestructible diecast alloy body
- Onboard color presets and macros
- High contrast OLED menu display
- Password protected menu lock
- IP65-rated for outdoor use
- DMX and W-DMX control

### SPECIFICATIONS

Light Source:	12 x 10W RGBW or RGBA LEDs
Beam Angle:	24° (optional versions: 15° or 45°)
Field Angle:	38°
Output:	912 LUX @ 5 meters
Color Mixing:	RGBW
Strobe:	0-30 Hz
Dimming:	4 dimming curve modes
Control Modes:	DMX, W-DMX, Standalone, Master/Slave
DMX Channels:	4 / 6 / 11
Built-in Programs:	Yes
Display:	OLED display menu with 4-button menu navigation
Mains:	100V-240V, 50/60Hz
Consumption:	110W
Power connections:	Seetronic IP65 PowerKon In/Out
Data connections:	Seetronic IP65 5-pin XLR In/Out
Housing:	Diecast aluminum
Finish:	Matte black
IP rating:	IP65
Cooling:	Passive
Operating Temperature:	-20°C to 40°C
Max. Housing:	65°C
Dimensions:	322 x 305 x 177 mm
Weight:	6.2 KG

### 3.10 CONNECTION OF THE DMX LINE

DMX connection employs standard XLR connectors. Use shielded pair-twisted cables with 120Ω impedance and low capacity.

The following diagram shows the connection mode:

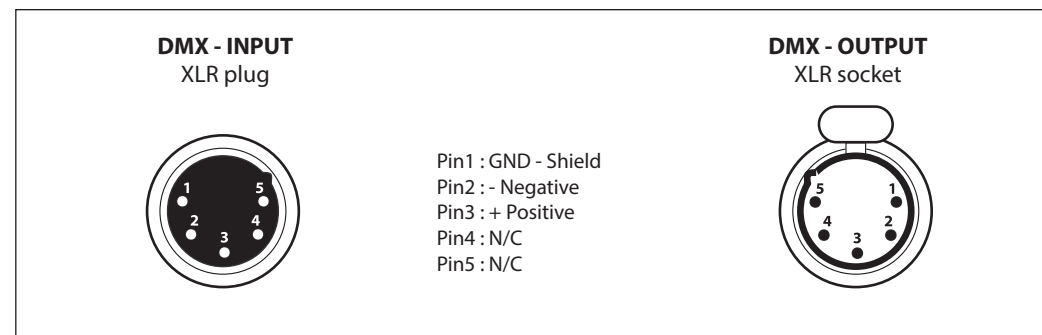

#### ATTENTION

The screened parts of the cable (sleeve) must never be connected to the system's earth, as this would cause faulty fixture and controller operation.

Over long runs can be necessary to insert a DMX level matching amplifier.

For those connections the use of balanced microphone cable is not recommended because it cannot transmit control DMX data reliably.

- Connect the controller DMX input to the DMX output of the first unit.
- Connect the DMX output to the DMX input of the following unit. Connect again the output to the input of the following unit until all the units are connected in chain.
- When the signal cable has to run longer distance is recommended to insert a DMX termination on the last unit.

### 3.11 CONSTRUCTION OF THE DMX TERMINATION

The termination avoids the risk of DMX 512 signals being reflected back along the cable when they reach the end of the line: under certain conditions and with certain cable lengths, this could cause them to cancel the original signals.

The termination is prepared by soldering a 120Ω 1/4 W resistor between pins 2 and 3 of the 5-pin male XLR connector, as shown in figure.

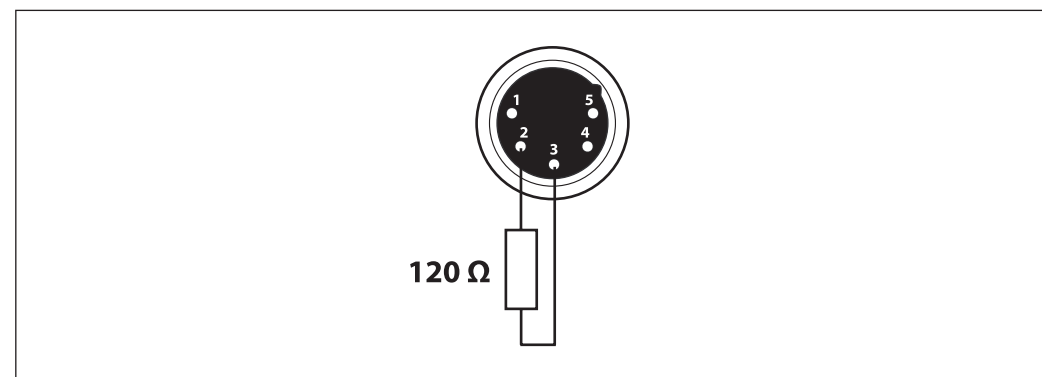

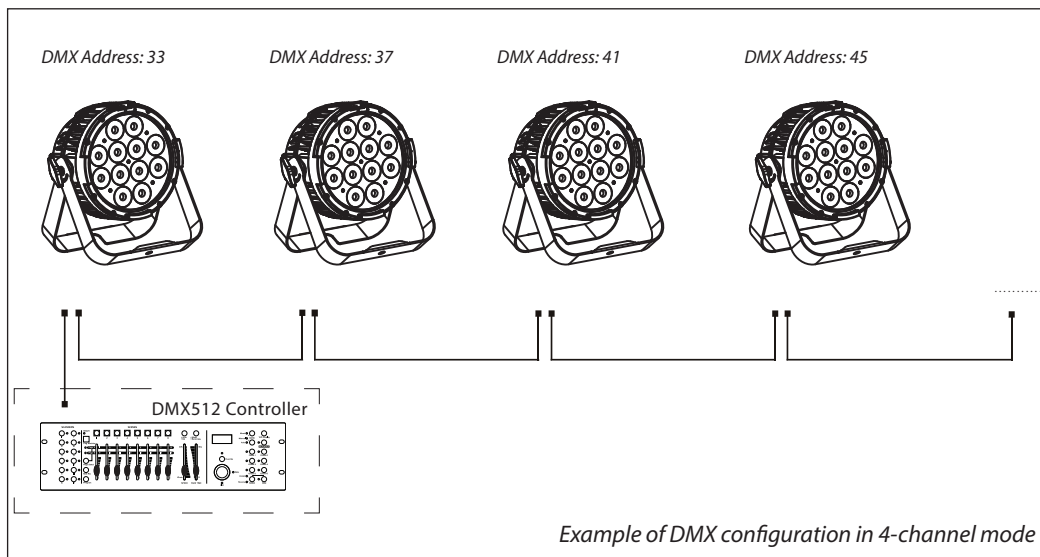

### 3.95 PHOTOMETRICS

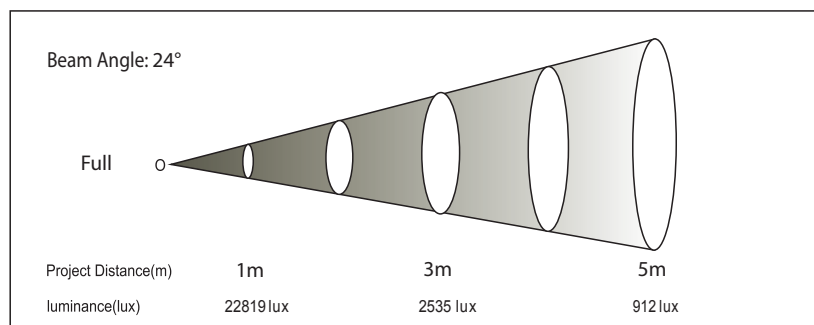

## - 1.2 - MAINTENANCE

### MAINTENANCE AND CLEANING THE UNIT

- Make sure the area below the installation place is free from unwanted persons during setup.
- Switch off the unit, unplug the main cable and wait until the unit has cooled down.
- All screws used for installing the device and any of its parts should be tightly fastened and should not be corroded.
- Housings, fixations and installation spots (ceiling, trusses, suspensions) should be totally free from any deformation.
- The main cables must be in impeccable condition and should be replaced immediately even when a small problem is detected.
- It is recommended to clean the front at regular intervals, from impurities caused by dust, smoke, or other particles to ensure that the light is radiated at maximum brightness. For cleaning, disconnect the main plug from the socket. Use a soft, clean cloth moistened with a mild detergent. Then carefully wipe the part dry. For cleaning other housing parts use only a soft, clean cloth. Never use a liquid, it might penetrate the unit and cause damage to it.

### TROUBLESHOOTING

Problems	Possible causes	Checks and remedies
Fixture does not light up	<ul style="list-style-type: none"> <li>• No mains supply</li> <li>• Dimmer fader set to 0</li> <li>• All color faders set to 0</li> <li>• Faulty LED</li> <li>• Faulty LED board</li> </ul>	<ul style="list-style-type: none"> <li>• Check the power supply voltage</li> <li>• Increase the value of the dimmer channels</li> <li>• Increase the value of the color channels</li> <li>• Replace the LED board</li> <li>• Replace the LED board</li> </ul>
General low light intensity	<ul style="list-style-type: none"> <li>• Dirty lens assembly</li> <li>• Misaligned lens assembly</li> </ul>	<ul style="list-style-type: none"> <li>• Clean the fixture regularly</li> <li>• Install lens assembly properly</li> </ul>
Fixture does not power up	<ul style="list-style-type: none"> <li>• No power</li> <li>• Loose or damaged power cord</li> <li>• Faulty internal power supply</li> </ul>	<ul style="list-style-type: none"> <li>• Check for power on power outlet</li> <li>• Check power cord</li> <li>• Replace internal power supply</li> </ul>
Fixture does not respond to DMX	<ul style="list-style-type: none"> <li>• Wrong DMX addressing</li> <li>• Damaged DMX cables</li> <li>• Bouncing signals</li> </ul>	<ul style="list-style-type: none"> <li>• Check control panel and unit addressing</li> <li>• Check DMX cables</li> <li>• Install terminator as suggested</li> </ul>

In case of technical issues that cannot be resolved following about troubleshooting tips, contact your authorized dealer for service.

### 1.3 OPERATING ELEMENTS AND CONNECTIONS

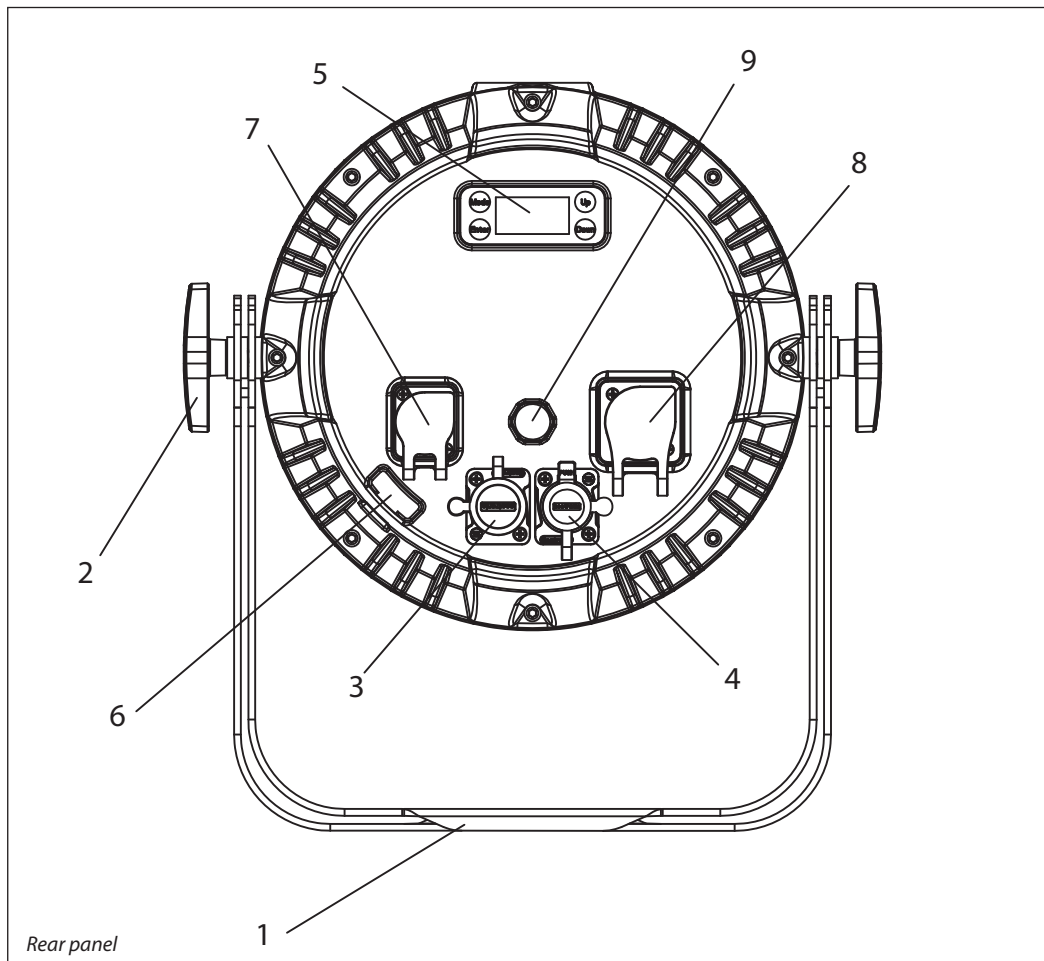

1. MOUNTING BRACKET
2. LOCKING KNOB for the mounting bracket
3. DMX IN (5-pin IP65 XLR):  
1 = ground, 2 = DMX-, 3 = DMX+, 4 N/C, 5 N/C
4. DMX OUT (5-pin IP65 XLR):  
1 = ground, 2 = DMX-, 3 = DMX+, 4 N/C, 5 N/C
5. CONTROL PANEL with display and 4 button used to access the control panel functions and manage them.
6. SAFETY ANCHOR POINT to attach safety cable
7. POWER IN (IP65 PowerKon): for connection to a socket (100-240V~/50-60Hz) via the supplied mains cable.
8. POWER OUT (IP65 PowerKon): connect to supply power to the next unit
9. Gore valve (to prevent condensation)

### 3.6 MASTER/SLAVE MODE

This mode will allow you to link up the units together without a controller. Choose a unit to function as the Master. The unit must be the first unit in line; other units will work as slave with the same effect.

- Press the button MENU so many times until the display shows **Master/Slave** and press the button ENTER.
- Press UP/DOWN to set the unit as master or slave (**Master/Slave**).
- Select the desired program (see section 3.4).
- Use standard DMX cables to daisy chain your units together via the DMX connector on the rear of the units. For longer cable runs we suggest a terminator at the last fixture (see page 13).

### 3.7 LINKING

Several units may be interconnected in order to control all further slave units to the same effect of the master unit.

1. Connect the DMX OUT of the master unit via 5-pin XLR cable to the DMX IN of the first slave unit.
2. Connect the DMX OUT of the first slave unit to the DMX IN of the second slave unit, etc. until all units are connected in a chain.

### 3.8 DMX CONFIGURATION

LITEPARPRO 12QX is equipped with different DMX configuration.

- Press the button MENU so many times until shows **DMX channel**, and press the button ENTER to confirm.
- Select the desired DMX configuration (**4Ch - 6Ch - 11Ch**) through the buttons UP/DOWN.

The tables on page 14 indicate the operating mode and DMX value. The LITEPARPRO 12QX is equipped with 5-pin XLR connections.

### 3.9 DMX ADDRESSING

- Press the button MENU so many times until the display shows **DMX address**, and press the button ENTER to confirm.
- Press UP/DOWN button to select the desired value (**001-509**). Press and hold to scroll quickly.
- Press ENTER button to store.
- Press the MENU button to go back or to meet the waiting time to exit the setup menu.

To operate the LITEPARPRO 12QX with a light controller, adjust the DMX start address for the first a DMX channel. If e. g. address 33 on the controller is provided for controlling the function of the first DMX channel, adjust the start address 33 on the LITEPARPRO 12QX.

The other functions of the light effect panel are then automatically assigned to the following addresses. An example with the start address 33 is shown below:

Number of DMX channels	Start address (example)	DMX Address occupied	Next possible start address for unit No. 1	Next possible start address for unit No. 2	Next possible start address for unit No. 3
4	33	33-36	37	41	45
6	33	33-38	39	45	51
11	33	33-43	44	55	66



### 3.3 MENU STRUCTURE (cont'd)

Wireless Setting	Receive On/Off	On	Default : Off
		Off	
Key Lock	Receive Reset	No	Default :No
		Yes	
Key Lock	On		Default: On
	Off		
Back Light	On		Default: On
	10S		
	20S		
	30S		
Information	Fixture Hours	<9999H>	
	Version	<V1.0>	
Reset Factory	No		Default: No
	Yes		

#### 3.35 W-DMX WIRELESS SETTING

The LITEPARPRO 12QX features an onboard W-DMX receiver. By default, W-DMX is OFF. To activate:

- Press the MENU button until the display shows **Wireless Setting**, then press ENTER.
- Press the UP/DOWN buttons to select **Receive On**, then press ENTER.
- To reset the onboard W-DMX receiver, select **Receive Reset**, then press ENTER.

#### 3.4 AUTO SHOW

If no DMX control signal is present at the DMX INPUT, the unit independently runs through its show programme provided that the blackout mode is switched off:

- Press the button MENU so many times until the display shows **Auto Show**, then press the button ENTER.
- Press the button UP/DOWN to switch between the show (**Auto 1 - 5**). The unit will operate in show mode.
- Using the button UP/DOWN to select the desired run speed slow-fast (**0-100**).
- Press the button ENTER to save the setting.

**IMPORTANT:** Programs **Auto 1 - 5** are fully pre-programmed and will not be altered by changes. Instead, **Manual Color** mode allows to combine the colors **Red - Green - Blue - White**.

- Press the button MENU so many times until the display shows **Static**, then press the button ENTER.
- Through the button UP/DOWN select **Manual Color**, then press the button ENTER.
- Select the color **Red - Green - Blue - White** through the buttons UP/DOWN.
- Press the button ENTER to confirm.
- Set the value (**000 - 255**), through the buttons UP/DOWN.
- Press the MENU button to go back or to meet the waiting time to exit the setup menu.

#### 3.5 STATIC MODE

This fixture has the ability to accept custom static color settings. Access these chases via the control panel on the back of the fixture.

- To enable the static mode, press MENU repeatedly until **Static** shows on the display.
- Press the button ENTER.
- Through the button UP/DOWN select **Fixture Color**, then press the button ENTER.
- Select the desired preset color (**R - G - B - W - GB - RB - RG - RGB - RW - GW - BW - RGW - RBW - GBW - RGBW**) using the button UP/DOWN.
- Press the button ENTER to save the setting.
- Press the MENU button to go back. Or, after a few seconds, the menu returns to the main screen.

## - 2 - INSTALLATION

### 2.1 MOUNTING

LITEPARPRO 12QX may be set up on a solid and even surface. The unit can also be mounted upside down to a cross arm. For fixing, stable mounting clips are required. The mounting place must be of sufficient stability and be able to support a weight of 10 times of the unit's weight.

When carrying out any installation, always comply scrupulously with all the regulations (particularly regarding safety) currently in force in the country in which the fixture's being used.

- Install the projector at a suitable location by means of the mounting bracket (2).
- Always additionally secure the projector with the safety rope from falling down. For this purpose, fasten the safety rope at a suitable position so that the maximum fall of the projector will be 20 cm.
- Adjust the projector and use the knob to slightly release or tighten the locking mechanism of the bracket if is necessary (1).

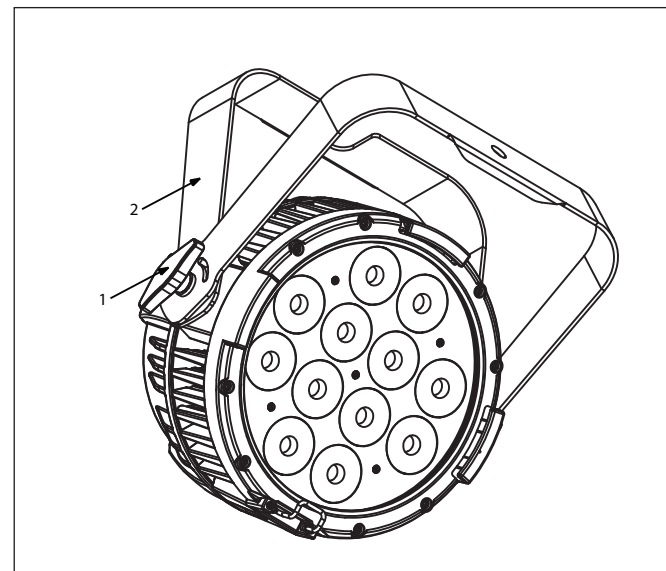

### 2.2 DIMENSIONS

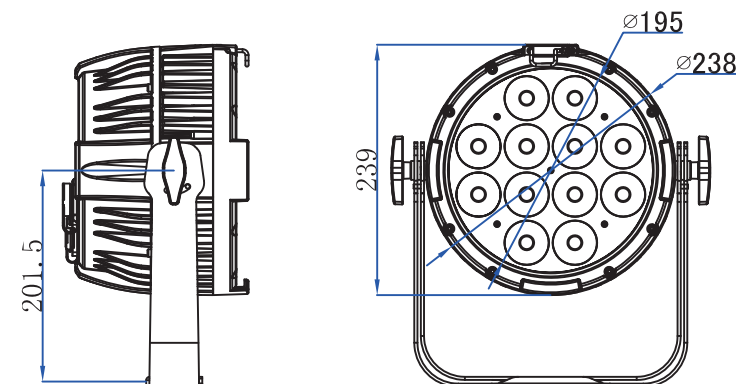

## - 3 - FUNCTIONS AND SETTINGS

### 3.1 OPERATION

Connect the supplied main cable to a socket (100-240V~/50-60Hz). Then the unit is ready for operation and can be operated via a DMX controller or it independently performs its show program in succession. To switch off, disconnect the mains plug from the socket. For a more convenient operation it is recommended to connect the unit to a socket which can be switched on and off via a light switch.

### 3.2 BASIC

Access control panel functions using the four panel buttons located directly underneath the black OLED display.

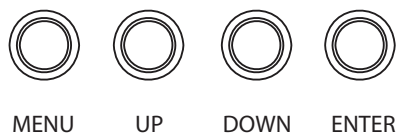
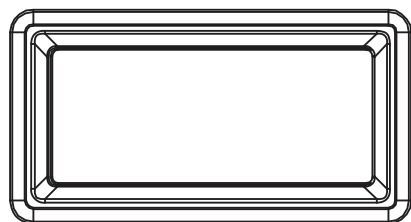

MENU	UP	DOWN	ENTER
Used to access the menu or to return a previous menu option	Navigates downwards through the menu list and increases the numeric value when in a function	Navigates upwards through the menu list and decreases the numeric value when in a function	Used to select and store the current menu or confirm the current function value or option within a menu

## 3.3 MENU STRUCTURE

DMX Address	<001>		Default: 001	
DMX Channel	4Ch		Default: 11CH	
	6Ch			
	11Ch			
Static	Fixed Color	R	RW	Default: RGBW
		G	GW	
		B	BW	
		W	RGW	
		GB	RBW	
		RB	GBW	
		RG	RGBW	
		RGB		
	Color Temperature	3000K		Default: 3000K
		4000K		
5000K				
6000K				
7000K				
8000K				
9000K				
Manual Color Mixer	Red	<0-255>	Default: RGBW=255	
	Green	<0-255>		
	Blue	<0-255>		
	White	<0-255>		
Auto Show	Auto 1	<1-100>	Default: Auto 1; Speed:100	
	Auto 2	<1-100>		
	Auto 3	<1-100>		
	Auto 4	<1-100>		
	Auto 5	<1-100>		
Master/Slave	Master		Default: Slave	
	Slave			
Dimmer Mode	Off		Default: Off	
	Dimmer 1			
	Dimmer 2			
	Dimmer 3			
White Balance	Manual	Red	<125-255>	Default: Off
		Green	<125-255>	
		Blue	<125-255>	
		White	<125-255>	
LED Frequency	600Hz		Default: 1200Hz	
	1200 Hz			
	2000 Hz			
	4000 Hz			
	25kHz			